

Micro gas preconcentrator made of a film of single-walled carbon nanotubes

Shuji Takada*, Takashi Nakai*, Theerapol Thurakitseree*,
Junichiro Shiomi*, Shigeo Maruyama*, Hideki Takagi**,
Masaki Shuzo****, Jean-Jacques Delaunay**** and Ichiro Yamada****

The development of a micro gas preconcentrator is crucial for the realization of miniaturized gas chromatography (micro-GC) systems which are expected to open up new applications such as breath analysis. One of the major problems with the reduction of preconcentrator size by miniaturization is the availability of a sorbent material which provides high enough concentration factor. Single-walled carbon nanotubes (SWNTs) are promising materials for high adsorption capacity. In this report, a gas preconcentrator having the depth of 40 μm and the volume of 1 μL was microfabricated. The synthesized SWNT film with a thickness of 30 μm was embedded in the micro gas preconcentrator by using the hot water-assisted detachment method. The small size of the fabricated micro gas preconcentrator and the use of SWNTs as the adsorbent material allow for achieving a concentration factor as high as 16000 for 2 ppm octane. This value is the highest of micro gas preconcentrators, reported to date, and sufficient for micro-GC detectors to concentrate trace analytes of interest for breath analysis. It is demonstrated that the micro gas preconcentrators using SWNTs as an adsorbent material have great potential to concentrate compounds.

Keywords : Micro gas preconcentrator, Adsorbent material, Single-walled carbon nanotube, Concentration factor

1. Introduction

Gas chromatography (GC) is the technique of choice for analysis of complex gaseous mixtures. A GC system typically consists of a separation column and a detector. Thanks to advances in microelectromechanical systems (MEMS) technology, miniaturization of GC systems (micro-GC) was made possible [1-2]. Further miniaturization and optimization of the GC components have been actively researched and developed [3-7]. The realization of micro-GC systems will open up new applications such as breath analysis, enabling non-invasive and fast screening/monitoring of infectious diseases. It is known that alkanes are endogenous breath molecules, which are usually associated with a broad range of diseases [8,9]. Alkanes are contained in human breath at very low concentrations in the ppb range, which are difficult to detect by conventional micro-GC detector [2,10]. Therefore, preconcentration of alkane analytes is needed.

A gas preconcentrator is crucial for achieving high sensitivity and improving the detection limit for the analytes of interest. Previous works on micro gas preconcentrators miniaturized by MEMS technology have been conducted, however, they suffer from low concentration factors [11-13]. The concentration factor is the most significant figure of merit for preconcentrators. Micro gas preconcentrators which have small inner volumes in the order of μL could not be packed with enough sorbent materials to be useful [11-16]. To enhance the concentration factor, the preconcentrator requires sorbent materials having higher sorption capacity than conventional sorbent materials such as Tenax TA and Carbopack. Therefore, one of the major challenges in developing microfabricated preconcentrators is the synthesis of

new sorbent materials with high enough sorption capacity for use in microfabricated preconcentrators.

Carbon nanotubes (CNTs) are attractive materials as the adsorbent material of alkanes owing to their chemical and thermal stability, a high surface-to-volume ratio, and a large affinity to the nonpolar compounds [17]. The chemical and thermal stability is required for CNTs to adsorb and desorb various organic compounds. High surface-to-volume ratio yields high adsorption capacity. Previous studies have demonstrated that CNTs have higher adsorption capacity than Carbopack, which is a graphitized carbon [18-20]. Single-walled carbon nanotubes (SWNTs) and multi-walled carbon nanotubes (MWNTs) in a conventional steel column have shown good adsorption capacity [18,19]. SWNTs are more suitable as adsorbent material than MWNTs, because SWNTs exhibit a large aspect ratio and higher effective surface area [18,19]. SWNTs have been also used as an adsorbent material in a micro gas preconcentrators, however the concentration factor was not quantitatively evaluated [21]. Therefore, the potential of SWNTs as an adsorbent material for use in micro gas preconcentrator is far from being demonstrated.

The aim of this report is to make a micro gas preconcentrator using SWNTs as an adsorbent material and realize a high concentration factor for an alkane analyte.

2. Experiment

2.1 Fabrication The thickness of SWNT films we used was 30 μm [15,16]. The SWNT film was obtained by the hot water-assisted detachment method. It is reported that SWNT films can be detached from the substrates on which the films were synthesized, and re-attached to other substrates in hot water above 60 $^{\circ}\text{C}$ [22]. This characteristic of SWNT films enabled us to readily embed SWNT films in a micro gas preconcentrator.

The depth of Si channel was designed to 40 μm to reduce the dead volume of the micro gas preconcentrator. With reference to previous works [11-13], the inner volume of a micro gas preconcentrator was designed to be 1 μL . This inner volume is smaller than any of the preconcentrator volumes reported in the

* Department of Mechanical Engineering, School of Engineering, The University of Tokyo

7-3-1 Hongo, Bunkyo-ku, Tokyo 113-8656, Japan

** National Institute of Advanced Industrial Science and Technology

1-2-1, Namiki, Tsukuba, Ibaraki 305-8564, Japan

*** JST, CREST

7-3-1 Hongo, Bunkyo-ku, Tokyo 113-8656, Japan

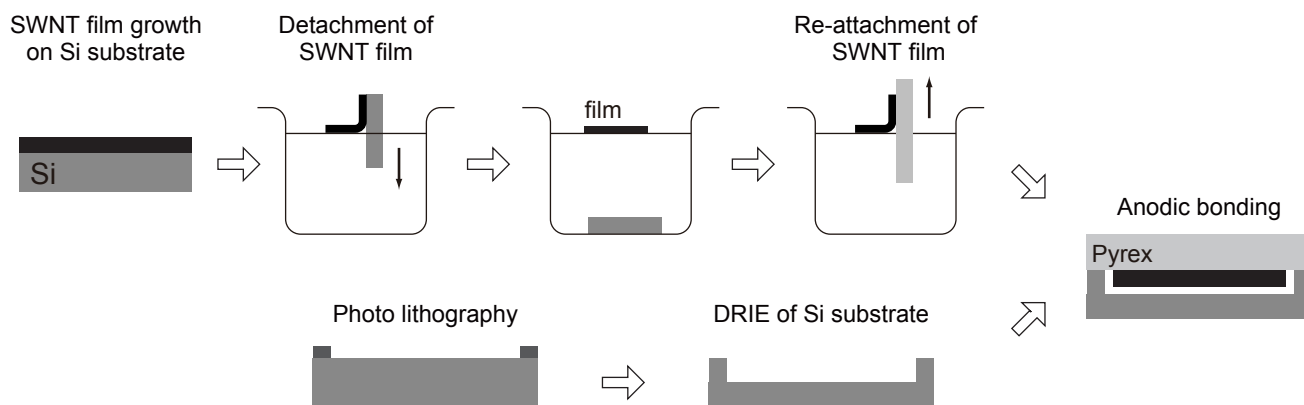

Fig. 1. Fabrication process of the micro gas preconcentrator using an SWNT film. The depth of the Si flow channel was 40 μm , and the volume of the fabricated micro gas preconcentrator was 1 μL .

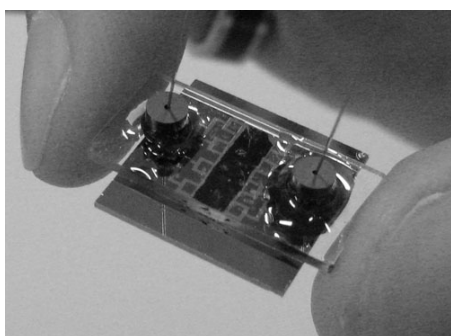

Fig. 2. Photograph of the fabricated micro gas preconcentrator with its embedded SWNT film. Deactivated fused silica capillary tubes were connected to the preconcentrator through two holes in the Pyrex lid glass.

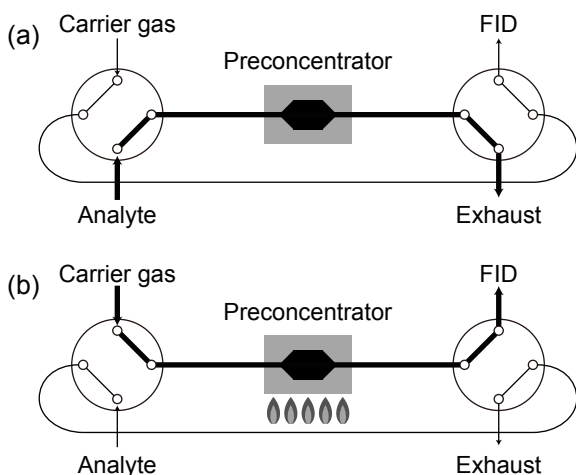

Fig. 3. Schematic of the experimental setup with (a) valves set in the adsorption position and (b) valves set in the desorption position.

literature.

The fabrication sequence of the micro gas preconcentrator using an SWNT film is illustrated in Fig. 1. First, an SWNT film was grown on the surface of a Si substrate by alcohol catalytic chemical vapor deposition (ACCVD) method [23]. We used molybdenum and cobalt as catalytic metals for the ACCVD process. The catalytic metals were dissolved (at the same weight concentration of 0.01 wt %) in ethanol to form a metal acetate

solution. The solution was dip-coated on the Si surface at a constant pull-up speed of 4 cm/min at room temperature. The substrate was then dried in an oven at 400 $^{\circ}\text{C}$ for 5 minutes. The ACCVD process was carried out in a quartz tube as follows. The substrate was heated to 800 $^{\circ}\text{C}$ in a furnace with a 300-sccm flow of argon gas containing 3% hydrogen (Ar/H₂ gas), so that the pressure inside the tube was kept at about 40 kPa. When the reaction temperature of 800 $^{\circ}\text{C}$ was reached, the gas flow was stopped, and ethanol vapor was introduced at a pressure of 1.3 kPa for 10 minutes. Second, the synthesized SWNT film on the substrate was detached in hot water and then it was re-attached to a Pyrex glass. The temperature of the water was set to 65 $^{\circ}\text{C}$. The detached SWNT films on the glass substrate were manually shaped by hand into a 3 \times 9 mm-rectangle. Third, another silicon substrate was patterned by photoresist masking and the pattern was etched using deep reactive ion etching (DRIE) to make a 40- μm -depth flow channel. Finally, the Pyrex glass loaded with an SWNT film was sealed on the etched silicon substrate by anodic bonding at 350 $^{\circ}\text{C}$ and 500 V in nitrogen atmosphere to prevent the SWNTs from oxidizing.

The fabricated micro gas preconcentrator had two holes (diameter of 1 mm) on a Pyrex glass side for the tubing connection. Two graphite ferrules (internal diameter of 0.5 mm) were used to make ports. They were fixed with a high temperature epoxy adhesive (526N, Aremco Products) on the glass. Deactivated fused silica capillary tubes (internal diameter of 150 μm and outer diameter of 220 μm) were connected to the ports. The connections were sealed with the epoxy adhesive. The completed micro gas preconcentrator is shown in Fig. 2.

2.2 Experimental setup To evaluate the concentration factor of a micro gas preconcentrator, tests of adsorption and desorption of analyte were carried out. Octane, which is one of alkanes present in human breath [9], was used as an analyte, and air was used as a diluted gas. The analyte vapor concentration in the diluted gas was accurately controlled by a gas generation apparatus (Double chamber permeator PD-1B-2, Gastec). The concentration factors of the micro fabricated preconcentrator were measured for 2 ppm octane. The flow rate of the analyte was kept constant at 2 mL/min during adsorption.

The experimental setup given in Fig. 3 was installed inside the oven of a conventional GC system (HP 6890 GC, Agilent). The built-in split/splitless inlet and the built-in flame ionization detector (FID) of the conventional GC system were connected to the setup via deactivated fused silica transfer tubes (internal

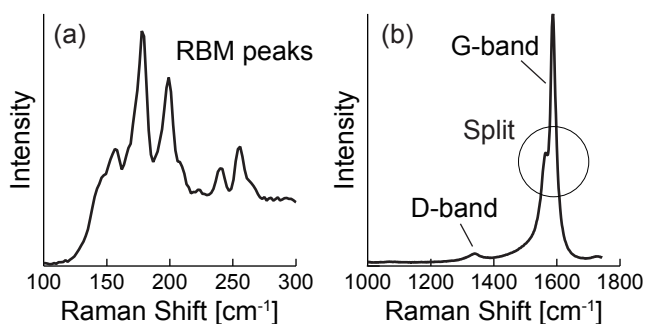

Fig. 4. (a) Low-frequency and (b) high-frequency parts of a representative resonance Raman spectrum of the SWNT film.

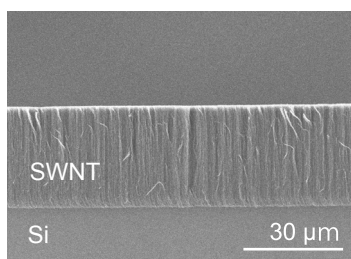

Fig. 5. An FE-SEM image of a cross section of the substrate where an SWNT film was synthesized. The thickness of the SWNT film was 30 μm .

diameter of 150 μm and outer diameter of 220 μm). The preconcentrator was heated by a ceramic heater, and the temperature of the preconcentrator was measured with a K-type thermocouple attached to the rear of the preconcentrator.

First, the analyte vapor was introduced into the micro gas preconcentrator in a constant time using two four-port zero-dead-volume valves (step shown in Fig. 3a). The analyte vapor was adsorbed on the SWNTs at the temperature of 25 $^{\circ}\text{C}$. The adsorption time was varied. Second, the two valves were switched and the micro gas preconcentrator was heated (step shown in Fig. 3b). The desorbed analyte from SWNTs was carried to the detector by the Helium carrier gas. The carrier gas flow rate was kept at a constant 4 mL/min. The peaks for the desorbed analyte were recorded using a data logger with a sampling frequency of 50 Hz and an A/D resolution of 16 bits.

3. Results and discussion

3.1 SWNT film characterization The synthesized SWNT film was characterized by resonance Raman spectroscopy (excitation at 488 nm) and field-emission scanning electron microscopy (FE-SEM), before the detachment of the SWNT film. Resonance Raman spectroscopy is used to estimate SWNT diameters and characterize their crystalline quality. Fig. 4 shows a typical resonance Raman spectrum. The low-frequency part of the spectrum is magnified in Fig. 4a, revealing radial breathing mode (RBM) peaks, which is strong evidence of SWNTs growth. These peaks indicate that the tube diameters of SWNTs were between 1 and 2 nm, although only the SWNTs that were resonant with the excitation laser were detected. The split of the G-band peaks around 1590 cm^{-1} is also unique to SWNTs. This is highlighted in Fig. 4b, where the high-frequency part of the spectrum is plotted. G-band peaks originate from in-plane vibrations of graphitic

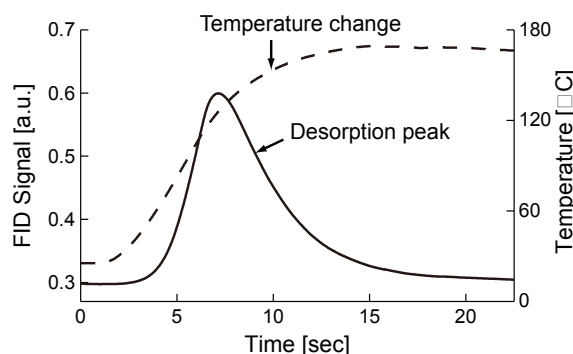

Fig. 6. The desorption peak from the micro gas preconcentrator filled with an SWNT film. Adsorption was done with 2 ppm octane for a duration of 180 min.

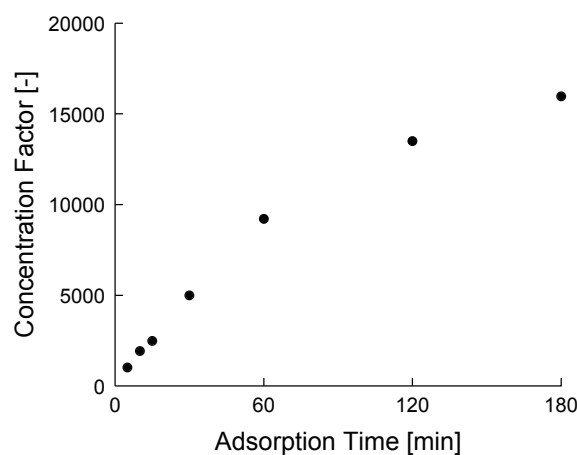

Fig. 7. The concentration factor as a function of the adsorption duration for 2 ppm octane.

lattices, and D-band peaks originate from defects in graphitic structures. The ratio of the G-band intensity to the D-band intensity was more than 20, indicating the growth of high-quality SWNTs.

The thickness of the synthesized SWNT film was measured by FE-SEM. Fig. 5 shows an FE-SEM image of a cross section of the silicon substrate with the SWNT film. Using several images at several locations of the cross section, we confirmed that the SWNT film on the silicon substrate has a uniform thickness of 30 μm .

3.2 Evaluation of concentration factor The concentration factor is obtained by calculating the ratio between the concentration of the desorbed analyte from the micro gas preconcentrator and the concentration of the analyte generated by the gas generation apparatus. The concentration of the desorbed analyte was calculated from dividing the volume of the desorbed analyte by the inner volume of the micro gas preconcentrator. The volume of the desorbed analyte was estimated by the FID signal corresponding to the desorption peak area. Fig. 6 is a measured desorption peak from the preconcentrator after 2 ppm octane was adsorbed for 180 min. Upon switching the valves, the FID signal was recorded and the temperature ramped up to 170 $^{\circ}\text{C}$.

The variation of the concentration factor with the adsorption time is shown in Fig. 7. The highest concentration factor obtained for 2 ppm octane adsorbed during 180 min was 16000. This value is the highest reported to date for micro gas preconcentrators and sufficiently large for micro-GC preconcentrators to concentrate

trace analytes of interest to breath analysis. To our knowledge, the highest concentration factor reported in the literature is 10000 [13]. The small volume of the fabricated micro gas preconcentrator and the use of SWNTs as the adsorbent material allow for achieving such a high concentration factor.

The concentration factor will further increase with increasing adsorption time because the microfabricated preconcentrator did not reach the adsorption limit (breakthrough point), even when octane was adsorbed for 180 minutes. However, the adsorption time is too long for practical use of preconcentrators and this point needs further consideration.

4. Conclusion

We proposed the use of SWNT film as an adsorbent material for microfabricated preconcentrators. An SWNT film having thickness of 30 μm was used as a high performance adsorbent material and embedded into a micro-fabricated gas preconcentrator having depth of 40 μm and inner volume of 1 μL . Evaluation of the concentration factor of the micro gas preconcentrator revealed that the highest concentration factor reported to date of 16000 for 2 ppm octane was achieved. It is demonstrated that the SWNT film based micro gas preconcentrators have great potential for achieving ultra-high preconcentration of alkanes.

Acknowledgments

This research was supported by CREST (JST) and the Global Center for Excellence for Mechanical Systems Innovation (MEXT). A part of this work was conducted in the Center for Nano Lithography & Analysis, The University of Tokyo. The photolithography masks were fabricated by using the ADVANTEST EB lithography apparatus, F5112+VD01, at the VLSI Design and Education Centre (VDEC) of The University of Tokyo.

References

- [1] S. C. Terry, J. H. Jerman, and J. B. Angell : "Gas-chromatographic air analyzer fabricated on a silicon-wafer", IEEE Transactions on Electron Devices, vol.26, no.12, pp.1880-1886 (1979)
- [2] C. J. Lu, W. H. Steinecker, W. C. Tian *et al.* : "First-generation hybrid MEMS gas chromatograph", Lab on a Chip, vol.5, no.10, pp.1123-1131 (2005)
- [3] T. Nakai, S. Nishiyama, M. Shuzo *et al.* : "Micro-fabricated semi-packed column for gas chromatography by using functionalized parylene as a stationary phase", Journal of Micromechanics and Microengineering, vol.19, no.6, 065032 (2009)
- [4] T. Nakai, J. Okawa, S. Takada *et al.* : "Carbon Nanotube Stationary Phase in a Microfabricated Column for High-Performance Gas Chromatography", 13 th International Symposium on Olfaction and Electronic nose, Brescia, Italy April 15-17, pp.249-252 (2009)
- [5] S. Li, J. C. Day, J. J. Park *et al.* : "A fast-response microfluidic gas concentrating device for environmental sensing", Sensors and Actuators A, vol.136 no.1, pp.69-79 (2007)
- [6] I. Voiculescu, R. A. McGill, M. E. Zagloul *et al.* : "Micropreconcentrator for enhanced trace detection of explosives and chemical agents", IEEE Sensors Journal, vol.6, no.5, pp.1094-1194 (2006)
- [7] S. Reidy, D. George, M. Agah *et al.* : "Temperature-programmed GC using silicon microfabricated columns with integrated heaters and temperature sensors", Analytical Chemistry, vol.79, no.7, pp.2911-2917 (2007)
- [8] E. Aghdasshi and J. P. Allard : "Breath alkanes as a marker of oxidative stress in different clinical conditions", Free Radical Biology And Medicine, vol.28, no.6, pp.880-886 (2000)
- [9] Poli D, Carbognani P, Corradi M, *et al.* : "Exhaled volatile organic compounds in patients with non-small cell lung cancer: cross sectional and nested short-term follow-up study", vol.6, no.71 (2005)
- [10] J. J. Whiting, C. J. Lu, E. T. Zellers *et al.* : "A portable, high-speed, vacuum-outlet GC vapor analyzer employing air as carrier gas and surface acoustic wave detection", Analytical Chemistry, vol.73, no.19, pp.4668-4675 (2001)
- [11] L. Voiculescu, M. Zaghoul, and N. Narasimhan : "Microfabricated chemical preconcentrators for gas-phase microanalytical detection systems", Trends in Analytical Chemistry, vol.27, no.4, pp.327-343 (2008)
- [12] B. Alfeeli, D. Cho, M. Ashraf-Khorassani *et al.* : "MEMS-based multi-inlet/outlet preconcentrator coated by inkjet printing of polymer adsorbents", Sensors and Actuators B, vol.133, no.1, pp.24-32 (2008)
- [13] B. Alfeeli and M. Agah : "Micro Preconcentrator with Embedded 3D Pillars for Breath Analysis Applications", 7th IEEE Sensors Conference, Lecce, Italy October 26-29, pp.736-739 (2008)
- [14] W. C. Tian, H. K. L. Chan, C. J. Lu *et al.* : "Multiple-stage microfabricated preconcentrator-focuser for micro gas chromatography system", Journal of Microelectromechanical systems, vol.14, no.3, pp.498-507 (2005)
- [15] F. blanco, X. vilanova, V. Fierro *et al.* : "Fabrication and characterisation of microporous activated carbon-based pre-concentrators for benzene vapours", Sensors and Actuators B, vol.132, no.1, pp.90-98 (2008)
- [16] I. Gracia, P. Ivanov, F. Blanco *et al.* : "Sub-ppm gas sensor detection via spiral μ -preconcentrator", Sensors and Actuators B, vol.132, no.1, pp.149-154 (2008)
- [17] C. M. Hussain, C. Saridara and S. Mitra : "Modifying the sorption properties of multi-walled carbon nanotubes via covalent functionalization", Analyst, vol.134, no.9, pp.1928-1933 (2009)
- [18] C. M. Hussain, C. Saridara and S. Mitra : "Microtrapping characteristics of single and multi-walled carbon nanotubes", Journal of Chromatography A, vol.1185, no.2, pp.161-166 (2008)
- [19] C. M. Hussain, C. Saridara and S. Mitra : "Carbon nanotubes as sorbents for the gas phase preconcentration of semivolatile organics in a microtrap", Analyst, vol.133, no.8, pp.1076-1082 (2008)
- [20] Q. L. Li, D. X. Yuan and Q. M. Lin : "Evaluation of multi-walled carbon nanotubes as an adsorbent for trapping volatile organic compounds from environmental samples", Journal of Chromatography A, vol.1026, no.1-2, pp.283-288 (2004)
- [21] E. H. M. Camera, P. Breuil, D. Briand *et al.* : "Influence of the adsorbent material in the performances of a micro gas preconcentrator", 13 th International Symposium on Olfaction and Electronic nose, Brescia, Italy April 15-17, pp.323-326 (2009)
- [22] Y. Murakami and S. Maruyama : "Detachment of vertically aligned single-walled carbon nanotube films from substrates and their re-attachment to arbitrary surfaces", Chemical Physics Letters, vol.422, no.4-6, pp.575-580 (2006)
- [23] S. Maruyama, R. Kojima, Y. Miyauchi *et al.* : "Low-temperature synthesis of high-purity single-walled carbon nanotubes from alcohol", Chemical Physics Letters, vol.360, no.3-4, pp.229-234 (2002)